

SPECIFICATIONS	
CONTACT CARRIER MATERIAL/COLOR	TPU/YELLOW
MOLDED HEAD MATERIAL/COLOR	TPU/YELLOW
CONTACT MATERIAL/PLATING	BRASS/GOLD
COUPLING NUT MATERIAL	BRASS/NICKEL
RATED CURRENT [A]	10.0 A
RATED VOLTAGE [V]	300 V
OUTER JACKET MATERIAL/COLOR	TPU/GREEN
CONDUCTOR INSULATION MATERIAL	PVC
NUMBER OF CONDUCTORS [AWG]	5x18 AWG
SHIELD	TINNED-COPPER BRAID
TEMPERATURE RANGE	-20°C to +80°C (-4°F to +176°F)
PROTECTION CLASS	MEETS NEMA 1,3,4,6P AND IEC IP67

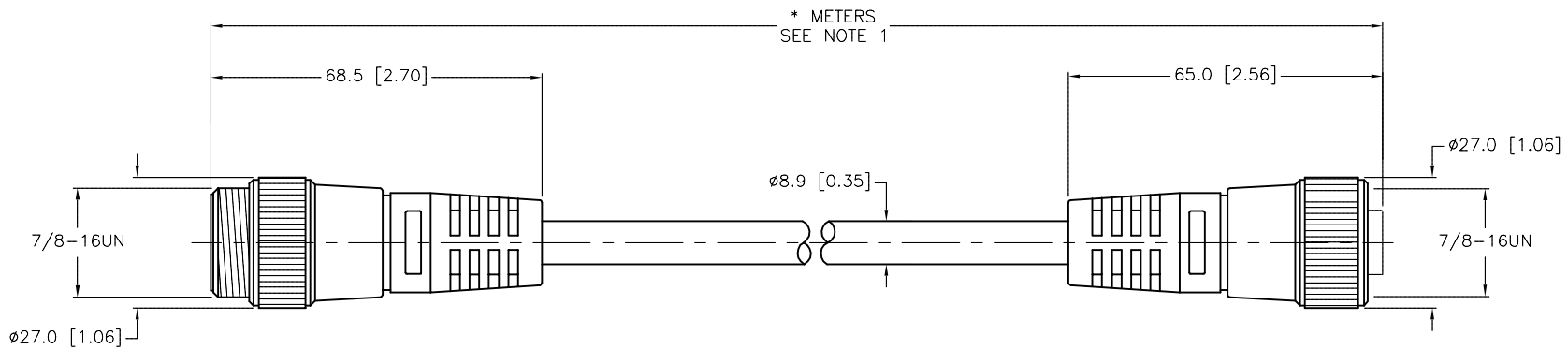

CABLE LENGTH	TOLERANCE *
ALL LENGTHS	+ 4% (OR 50mm) OF LENGTH - 0% (OR 0mm) OF LENGTH WHICHEVER IS GREATER
STRIP LENGTH	TOLERANCE *
0-7mm	±0.5mm
8-29mm	±1.0mm
30-49mm	±2.0mm
50-69mm	±3.0mm
70-100mm	±4.0mm
OVER 100mm	±5.0mm

* UNLESS OTHERWISE SPECIFIED

SOURCE DRAWING - FOR REFERENCE ONLY

NOTES:

- "*" INDICATES CABLE LENGTH IN METERS. CONTACT TURCK TO ORDER SPECIFIC LENGTHS.
- "/CS11643" DESIGNATES 5x18 AWG CABLE. FLEXLIFE 5 TO 10 MILLION, BUILT FOR C-TRACK

RELATED DOCUMENTS 1. 2. 3. 4.	3RD ANGLE PROJECTION 	THIS DRAWING IS CONFIDENTIAL AND THE PROPERTY OF TURCK INC. USE OF THIS DOCUMENT WITHOUT WRITTEN PERMISSION IS PROHIBITED.		3000 CAMPUS DRIVE MINNEAPOLIS, MN 55441 1-800-544-7769 (763) 553-7300 (763) 553-0708 fax www.turck.us	
	MATERIAL	DRFT RDS	DATE 09/27/07	DESCRIPTION RSM RKM 56-*M/CS11643	
FINISH	ALL DIMENSIONS DISPLAYED ON THIS DRAWING ARE FOR REFERENCE ONLY	DSGN	SCALE 1=1.5	IDENTIFICATION NO.	
CONTACT TURCK FOR MORE INFORMATION		UNIT OF MEASUREMENT MILLIMETER [INCH]		REV E	
E DRAWING PROCESSED AS PART OF ECO 33971		CBM 04/06/11 33971		DO NOT SCALE THIS DRAWING	
REV DESCRIPTION		BY DATE ECO NO.		FILE: 777020104 SHEET 1 OF 1	

E	DRAWING PROCESSED AS PART OF ECO 33971	CBM	04/06/11	33971
REV	DESCRIPTION	BY	DATE	ECO NO.